

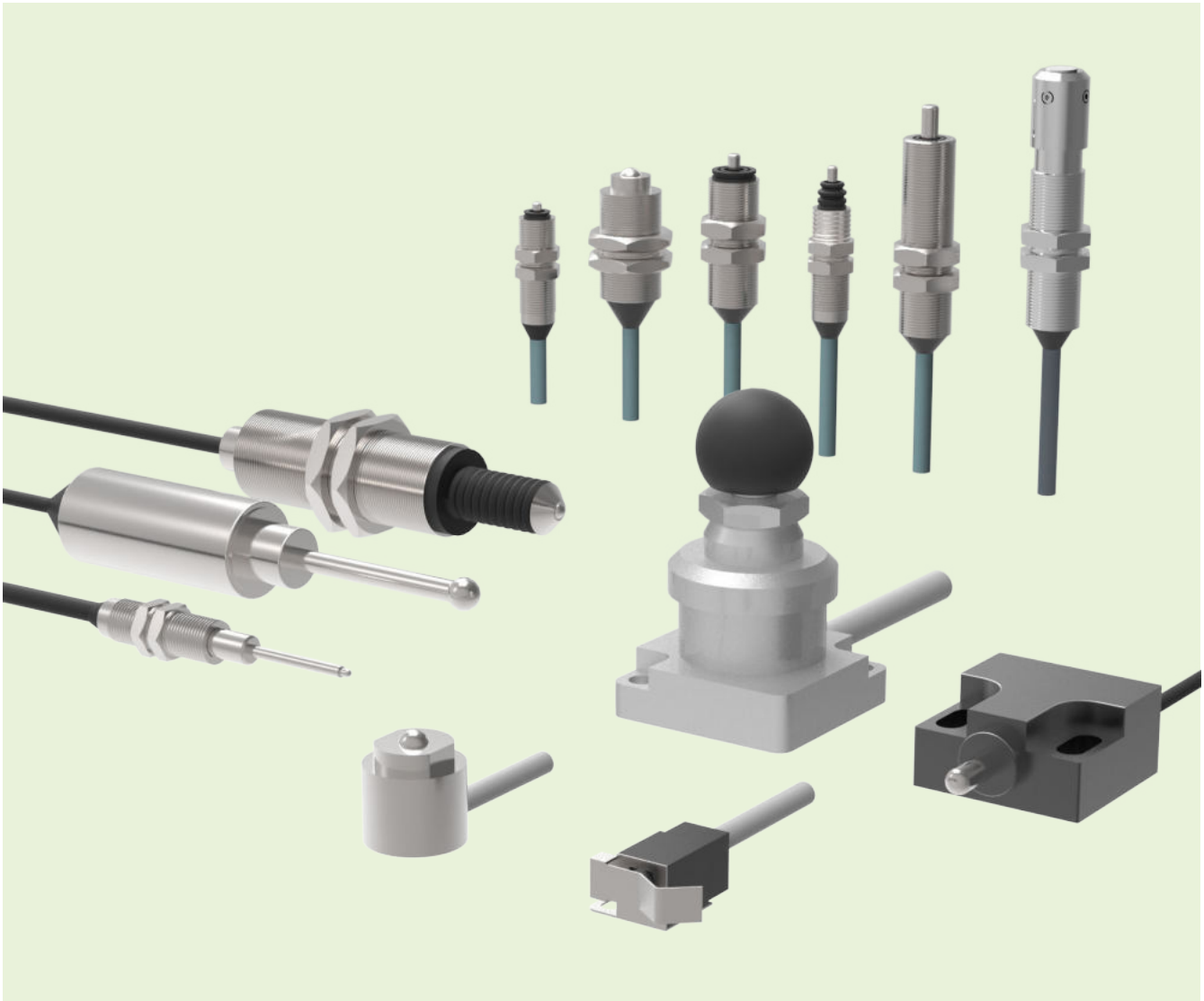

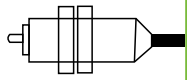

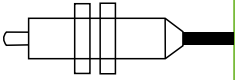

Precision Contact Sensors

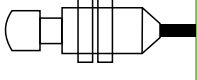
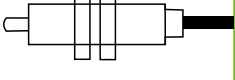
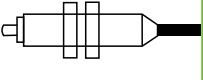
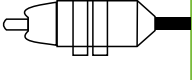
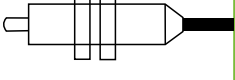

- Magnetic detection usage, reliable performance, long service life .
- Repeat accuracy up to 0.001mm .
- With high precision spring; Min. detected tightening torque 0.3N.
- Customization is available as requested.
- One sensor can detect 4 action points simultaneously.



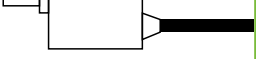





Appearance	Position Repeat Accuracy	Mounting Size	Range	Operating	Main Model No.	Pages
	± 0.001mm	M8X24	1.5mm	0.3N	MR-T8	H-03
	± 0.001mm	M8X35	3mm	0.6N	MR-T8A (HOT)	
	± 0.001mm	M8X38.2	3mm	0.6N	MR-T8B (HOT)	
	± 0.001mm	M8X39	3mm	0.6N	MR-T8P	
	± 0.001mm	M6X21	1.2mm	0.3N	MR-T6 (HOT)	
	± 0.001mm	M10X27	3mm	0.8N	MR-T10	
	± 0.01mm	M10X21.2	1mm	H:5N J:0.5N	MR-T10B	
	± 0.001mm	M14X37	6mm	0.5~1.5N	MR-T5Z	H-04
	± 0.01mm	φ 14X80.5	5mm	H:2N J:0.8N	MR-T1X	
	± 0.01mm	M6X25	1.2mm	0.3N	MR-T6N	
	± 0.01mm	26X55	360° direction: 3±0.5mm	H:3N J:0.5N	MR-T4X	
	± 0.01mm	φ 12X12.9	1mm	H:7N J:0.5N	MR-T12B	
	± 0.002mm	Leverage: 18X7.4X15.7 Button: 10.4X7.4X14.9	Leverage: 0.3N Button: 0.6N	MR-T1QA	
	± 0.01mm	21X22	8mm	0.8N	MR-T93Q	

- Fiber Optic
- Slot Sensors
- Photoelectric
- Laser
- Proximity
- Displacement
- Magnetic
- Contact
- Area
- Ultrasonic
- Vibration
- Temperature
- Cables
- Tester

Guidance

- Contact
- Contact

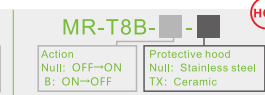







Contact

Appearance				
Main Model No.	MR-T8	MR-T8A	MR-T8B	MR-T8P
Operating voltage	5~24V DC			
Position repeat accuracy	±0.001mm			
Range	1.5mm		3mm	
Operating force	0.3N		0.6N	
PT	0.4~0.7mm			
MD	<0.1mm			
Action frequency	120 times/min			
Output type	NPN NO/NC selectable			
Output current	No indicator: ≤ 15mA, with indicators: ≤ 12mA			
Current consumption	No indicator: ≤ 15mA, with indicators: ≤ 12mA			
Voltage withstability	AC1000V 1min			
Insulation strength	250V DC ≥20MΩ			
Ambient temperature	-20°C~+85°C, No freezing			
Ambient humidity	20%~95%RH, No condensation			
Housing, nuts and shaft material	SUS303			
Indicator	Approx 100mm away from the main body			
Mounting	With M8 nuts, tightening torque 5N · m			
Degree of protection	IP67			
Connection	1M 3core cable			
Model No.	 MR-T8- - - <ul style="list-style-type: none"> Action: Null: OFF—ON B: ON—OFF 	 MR-T8A- - - <ul style="list-style-type: none"> Action: Null: OFF—ON B: ON—OFF 	 MR-T8B- - - <ul style="list-style-type: none"> Action: Null: OFF—ON B: ON—OFF Protective hood: Null: Stainless steel, TX: Ceramic 	 MR-T8P- - - <ul style="list-style-type: none"> Action: Null: OFF—ON B: ON—OFF

Appearance			
Main Model No.	MR-T6	MR-T10	MR-T10B
Operating voltage	5~24V DC		
Position repeat accuracy		±0.001mm	±0.01mm
Range	1.2mm	3mm	1mm
Operating force	0.3N	0.8N	H:5N, J:0.5N
PT	0.4~0.7mm	Single: 0.4~0.7mm; Dual: 1.0±0.15mm	0.3~0.6mm
MD	<0.1mm		
Action frequency	120 times/min		
Output type	NPN NO/NC selectable		
Output current	No indicator: ≤ 15mA, with indicators: ≤ 12mA		
Current consumption	No indicator: ≤ 15mA, with indicators: ≤ 12mA		
Voltage withstability	AC1000V 1min		
Insulation strength	250 V DC ≥20MΩ		
Ambient temperature	-20~+85°C, No freezing		
Ambient humidity	20~95%RH, No condensation		
Housing, nuts and shaft material	SUS303		
Indicator	Approx 100mm away from the main body		
Mounting	With M6 nuts, tightening torque 2N · m	With M10 nuts, tightening torque 12N · m	
Degree of protection	IP67	IP65	
Connection	3core cable(Length: 1m)		
Model No.	 MR-T6- - - <ul style="list-style-type: none"> Action: Null: OFF—ON B: ON—OFF 	 MR-T10- - - <ul style="list-style-type: none"> Built-in sensors: S: Single output, D: Dual output Action: Null: OFF—ON B: ON—OFF 	 MR-T10B- - - <ul style="list-style-type: none"> Action: Null: OFF—ON B: ON—OFF Operating force: H: 5N, J: 0.5N Indicator on cables: Null: No indicator, LED: With indicators

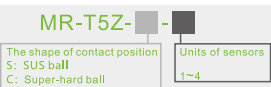
Up to 4 action points available

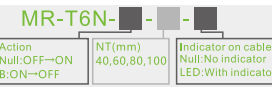
360° degree detection

Appearance				
Main Model No.	MR-T5Z	MR-T1X	MR-T6N	MR-T4X
Operating voltage	5~24V DC			
Position repeat accuracy	±0.001mm		±0.01mm	
Range	6mm	5mm	1.2mm	Direction:360° 3±0.5mm
Operating force	0.5~1.5N	H: 2N, J: 0.8N	0.3N	H: 3N, J: 0.5N
PT	0.1~0.4mm	0.4~0.7mm
OP	2±0.5mm	1.5±0.5mm
MD	<0.08mm		<0.1mm	
Action frequency	120 times/min			
Output type	NPN (NO)		NPNNO/NCselectable	
Output current	No indicator: ≤ 15mA, with indicators: ≤ 12mA			
Current consumption	No indicator: ≤ 15mA, with indicators: ≤ 12mA			
Voltage withstability	AC1000V 1min			
Insulation strength	250 V DC ≥20MΩ			
Ambient temperature	-20°C~+85°C, No freezing			
Ambient humidity	20%~95%RH, No condensation			
Units of sensors	1~4		
Material	Rubber protective tube: NBR; housing & nuts: SUS3003	SUS303		Housing: cast Zinc alloy; ball handle: black phenolic
Indicator	Approx 100mm away from the main body			
Mounting	With M14 nuts, tightening torque 18N·m	With M6 nuts, tightening torque 2N·m
Degree of protection	IP65			
Connection	1M 3core cable			
Model No.	 <p>MR-T5Z- - - -</p> <p>The shape of contact position S: SUS ball C: Super-hard ball</p> <p>Units of sensors 1~4</p>	 <p>MR-T1X- - - -</p> <p>Operating force H: 2N J: 0.8N</p> <p>Indicator on cables Null: No indicator LED: With indicators</p>	 <p>MR-T6N- - - -</p> <p>Action Null: OFF→ON B: ON→OFF</p> <p>NT(mm) 40, 60, 80, 100</p> <p>Indicator on cables Null: No indicator LED: With indicators</p>	 <p>MR-T4X- - - -</p> <p>Operating force H: 2N J: 0.8N</p> <p>Indicator on cables Null: No indicator LED: With indicators</p>

Small tightening torque

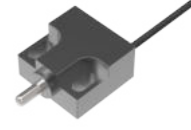
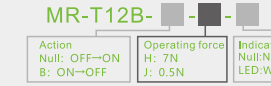
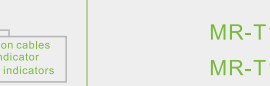
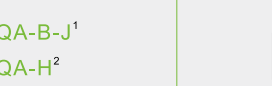
Appearance			
Main Model No.	MR-T12B	MR-T1QA	MR-T93Q
Operating voltage	5~24V DC		MR-T93Q: 12~24V DC; MR-T93Q-E: 5~24V DC
Position repeat accuracy	±0.01mm	±0.002mm	±0.01mm
Range	1mm	0.7mm	8mm
Operating force	H: 7N, J: 0.5N	Leverage: 0.3N; Button: 0.6N	0.8N
PT	0.3~0.6mm	0.1~0.4mm	0.3~0.8mm
MD		<0.1mm	
Action frequency	120 times/min		
Output type	NPN NO/NC selectable		
Output current	No indicator: ≤ 15mA, with indicators: ≤ 12mA		MR-T93Q: ≤80mA; MR-T93Q-E: ≤15mA
Current consumption	No indicator: ≤ 15mA, with indicators: ≤ 12mA		
Voltage withstability	AC1000V 1min		
Insulation strength	250 V DC ≥20MΩ		
Ambient temperature	-20°C~+85°C, No freezing		
Ambient humidity	20%~95%RH, No condensation		
Material	SUS303	Housing; heat resistant ABS; rubber seal: NBR	Axis: SUS303; Housing: Glass FB reinforced PBT
Indicator	Approx 100mm away from the main body	MR-T93Q: Red; MR-T93Q-E: Null
Mounting	M3 nuts, tightening torque 0.3N·m
Degree of protection	IP65		
Connection	1M 3core cable		
Model No.	 <p>MR-T12B- - - -</p> <p>Action Null: OFF→ON B: ON→OFF</p> <p>Operating force H: 7N J: 0.5N</p> <p>Indicator on cables Null: No indicator LED: With indicators</p>	 <p>MR-T1QA-B-J¹</p> <p>MR-T1QA-H²</p>	 <p>MR-T93Q- - - -</p> <p>Output current Null: 80mA E: 15mA</p> <p>Action Null: OFF→ON B: ON→OFF</p>

1: MR-T1QA-B-J: indicates action ON → OFF; low operating force;
2: MR-T1QA-H: indicates action OFF → ON; operating force standard;

- Fiber Optic
- Slot Sensors
- Photoelectric
- Laser
- Proximity
- Displacement
- Magnetic
- Contact
- Area
- Ultrasonic
- Vibration
- Temperature
- Cables
- Tester

Guidance

- Contact
- Contact

Contact

Dimensions(Unit:mm)

Contact

MR-T8

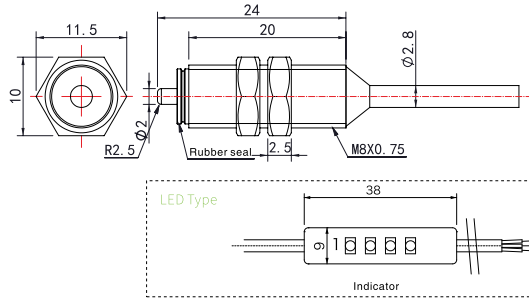

MR-T8A

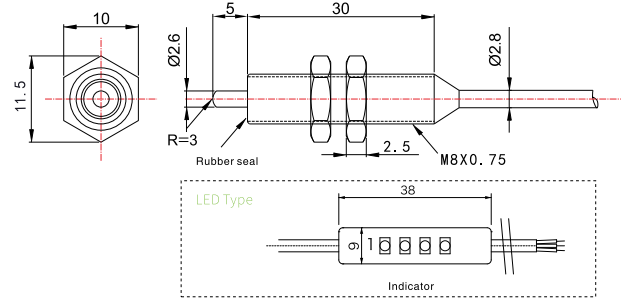

MR-T8B

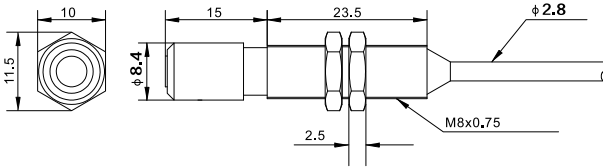

MR-T6

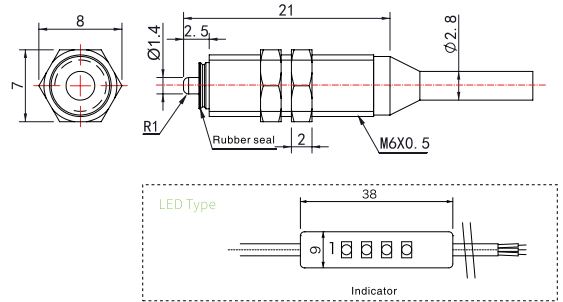

MR-T8P

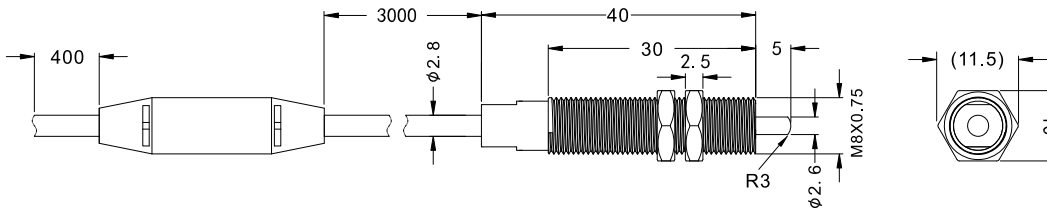

MR-T10

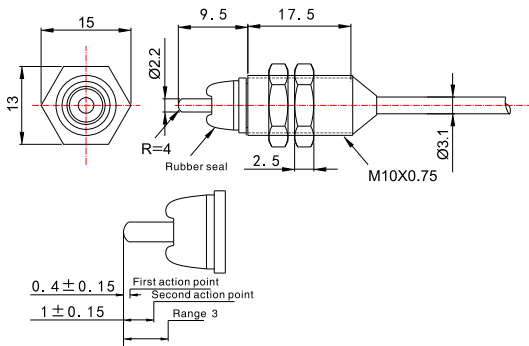

MR-T10B

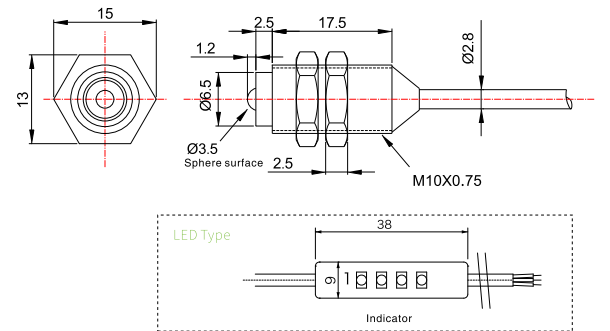

MR-T5Z

